



Fibre optic cabinets | Electricity cabinets and components | Customized Enclosures |

# Orion – Climate Cabinet Solutions

Real-world protection for your active equipment network in a low-noise environment



## **Before we get too high-flying and technical about cabinets – let's get down to earth ...**

Do you remember what happens when you actually place your laptop in your lap? That's right. Gets burning hot, doesn't it? Unpleasant for you and bad for your PC – as components and delicate electronics suffer and gradually deteriorate when the heat just keeps climbing with no proper means of escape.

Most active equipment reacts that way to heat – and to freezing cold weather conditions, dust, rain and humidity; especially when we are talking large-scale outdoor projects involving fibre optic components, multimedia networks, traffic regulation systems or equipment for telecommunication.

You shouldn't worry about it though. Triax climate control cabinets solve these problems for you.

But let's be honest with you right from the start: there's really nothing sexy about cabinets – all you need them for is to protect your precious active equipment inside. That's it.

Since that's probably vital to the outcome of all your projects – whether you are an installer, engineer or project manager – customising and building climate control cabinets you can trust is something we are dead serious about. Every single time.

As a matter of fact, if you get some free time on your hands, why not inspect a few Triax cabinets for yourself? You'll find them in small towns and big cities, in residential areas, the countryside and industrial areas.

Often you'll see them in discreet green or grey colours, their high-quality finish allowing them to blend perfectly into their surroundings. But don't be surprised if you find a cabinet that looks a little older in style, but no less capable in use: rest assured, we've got lots of Triax cabinets out there, still doing their job admirably 40+ years after they were first installed.

And years from now, we'll still be here when you need us for your next network project.

**Now let's turn the page and find that cabinet you are looking for.**

# Contents

<b>The standard solution</b>	
Single cabinet.....	4
Double cabinet.....	4
Configuration of single and double cabinets.....	5
Internal dimensions.....	5
<b>Fixed base/plinth or in-ground root installation</b>	
Integrated base/plinth for pre-fixed base mounting.....	6
Root assembly for in-ground installation.....	6
<b>A solution - an example / transport</b>	
A solution - an example.....	7
Transport – how to lift your cabinets safely.....	7
<b>Technical information</b>	
Standards.....	8
Corrective maintenance – how to keep your cabinets in good shape.....	8
<b>Climate conditions and control</b>	
Flow diagram, active and passive convection.....	8
How to pick the proper climate control equipment for your project.....	10
Heat absorption from sunlight – and how to deal with it.....	10
What we mean by air humidity (condensation) – a definition.....	11
<b>Contact information.....</b>	<b>12</b>

# The standard solution

## Single cabinet



Type	CCO 136	CCO 138	CCO 176	CCO 178
<b>Part number<sup>1</sup></b>	<b>255501</b>	<b>255503</b>	<b>255505</b>	<b>255507</b>
Height in units (U)	24	24	33	33
H: Height (mm)	1400	1400	1800	1800
D: Depth (mm)	630	830	630	830
W: Width (mm)	754	754	754	754
Net weight (kg)	160	177	173	195
Maximum equipment load (kg)	250	250	250	250
Maximum total weight (kg)	410	427	423	445
Colour <sup>2</sup>	RAL 7035	RAL 7035	RAL 7035	RAL 7035

1) Refers to the part number of the entire cabinet

2) Contact Triax for more information on colour options

## Double cabinet



Type	CCO 136D	CCO 138D	CCO 176D	CCO 178D
<b>Part number<sup>1</sup></b>	<b>255502</b>	<b>255504</b>	<b>255506</b>	<b>255508</b>
Height in units (U)	2 x 24	2 x 24	2 x 33	2 x 33
H: Height (mm)	1400	1400	1800	1800
D: Depth (mm)	630	830	630	830
W: Width (mm)	1454	1454	1454	1454
Net weight (kg)	276	296	289	326
Maximum equipment load (kg)	420	420	420	420
Maximum total weight (kg)	696	716	709	746
Colour <sup>2</sup>	RAL 7035	RAL 7035	RAL 7035	RAL 7035

1) Refers to the part number of the entire cabinet

2) Contact Triax for more information on colour options

# The standard solution

## Configuration of single and double cabinets



Single cabinet:



Double cabinet:

Type	CCO 136	CCO 138	CCO 176	CCO 178	CCO 136D	CCO 138D	CCO 176D	CCO 178D
Part number <sup>1</sup>	255501	255503	255505	255507	255502	255504	255506	255508
Frame	255701	255702	255703	255704	2 x 255701	2 x 255702	2 x 255703	2 x 255704
Left-hand side panel	255718	255719	255720	255721	255718	255719	255720	255721
Right-hand side panel	255722	255723	255724	255725	255722	255723	255724	255725
Back panel	255715	255715	255716	255716	2 x 255715	2 x 255715	2 x 255716	2 x 255716
Roof/top panel	255705	255706	255705	255706	2 x 255705	2 x 255706	2 x 255705	2 x 255706
Left door	-	-	-	-	255707	255707	255708	255708
Right door	255711	255711	255712	255712	255711	255711	255712	255712
Cable/duct access plate	255726	255727	255726	255727	2 x 255726	2 x 255726	2 x 255726	2 x 255726
19"/ETSI rack kit	255728	255728	255729	255729	2 x 255728	2 x 255728	2 x 255729	2 x 255729
Terminal board	255739	255739	255739	255739	2 x 255739	2 x 255739	2 x 255739	2 x 255739
Integrated plinth cover	255717	255717	255717	255717	2 x 255717	2 x 255717	2 x 255717	2 x 255717
Clip nuts, set of 4	3 x 255738	3 x 255738	3 x 255738	3 x 255738	6 x 255738	6 x 255738	6 x 255738	6 x 255738

1) Refers to the part number of the entire cabinet

## Internal dimensions

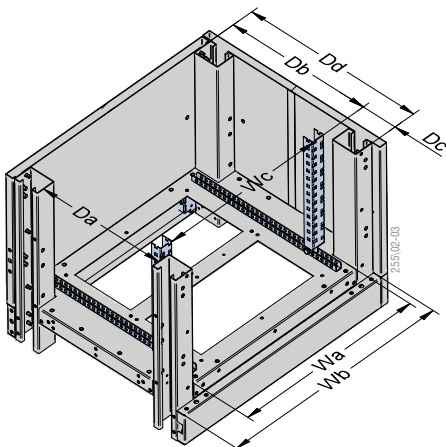

Type	CCO 136	CCO 138	CCO 176	CCO 178
<b>Side:</b>				
Da: Frame upright separation (mm)	390	590	390	590
Db: Distance <sup>1</sup> from rack rail to back panel (mm)	62-520	68-715	62-520	68-715
Db: As above with heat exchanger in door (mm)	360	555	360	555
Dc: Distance <sup>1</sup> from rack rail to door (mm)	25-483	30-677	25-483	30-677
Dd: Total distance from inside of door to rear panel (mm)	545	745	545	745
<b>Front:</b>				
Wa: Front opening clearance (mm)	580	580	580	580
Wb: Frame upright external dimensions (mm)	700	700	700	700
Wc: ETSI standard rack rail spacing (mm)	500	500	500	500
Wc: 19" standard rack rail spacing (mm)	450	450	450	450

1) Gradual adjustment – in steps of 16 mm

# Fixed base/plinth or in-ground root installation

## Integrated base/plinth for pre-fixed base mounting

Your Orion cabinet comes ready-to-go with an integrated base/plinth to mount on a prepared concrete, or similar solid foundation. Our built-in cable/duct access plates allow you to connect to your equipment quickly and provide secure protection for your installation.

## Root assembly for in-ground installation

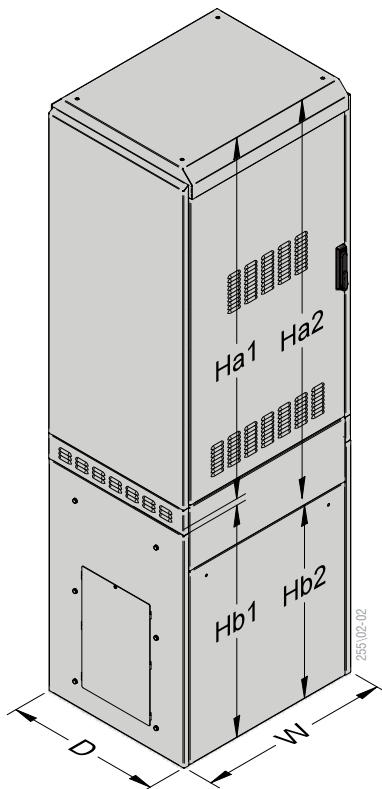

Type	CCO 136	CCO 138	CCO 176	CCO 178
Ha1: Height above ground – min. <sup>1</sup> (mm)	1400	1400	1800	1800
Ha2: Height above ground – max. <sup>2</sup> (mm)	1550	1550	1950	1950
Hb1: Burial depth – min. <sup>1</sup> (mm)	900	900	900	900
Hb2: Burial depth – max. <sup>2</sup> (mm)	750	750	750	750
D: Depth (mm)	630	830	630	830
W: Width (mm)	754	754	754	754

- 1) Ha1 and Hb1 apply when you need to fit the in-ground root flush to ground level
- 2) Ha2 and Hb2 when you want to have unrestricted access to the in-ground root, part-installed in the ground

Our root assembly allows you to install your cabinet/root assembly within a height range, to suit local requirements.

Type	CCO 136	CCO 138	CCO 176	CCO 178
In-ground root single cabinet	255510	255512	255510	255512
In-ground root double cabinet	255511	255513	255511	255513

The in-ground root is prepared for the installation of a battery tray. And when you mount the cabinet the integrated plinth cover can, when removed, give you easy access to cables and other equipment below the cabinet.



In-ground root single cabinet



In-ground root double cabinet

# A solution – an example / transport

## A solution – an example

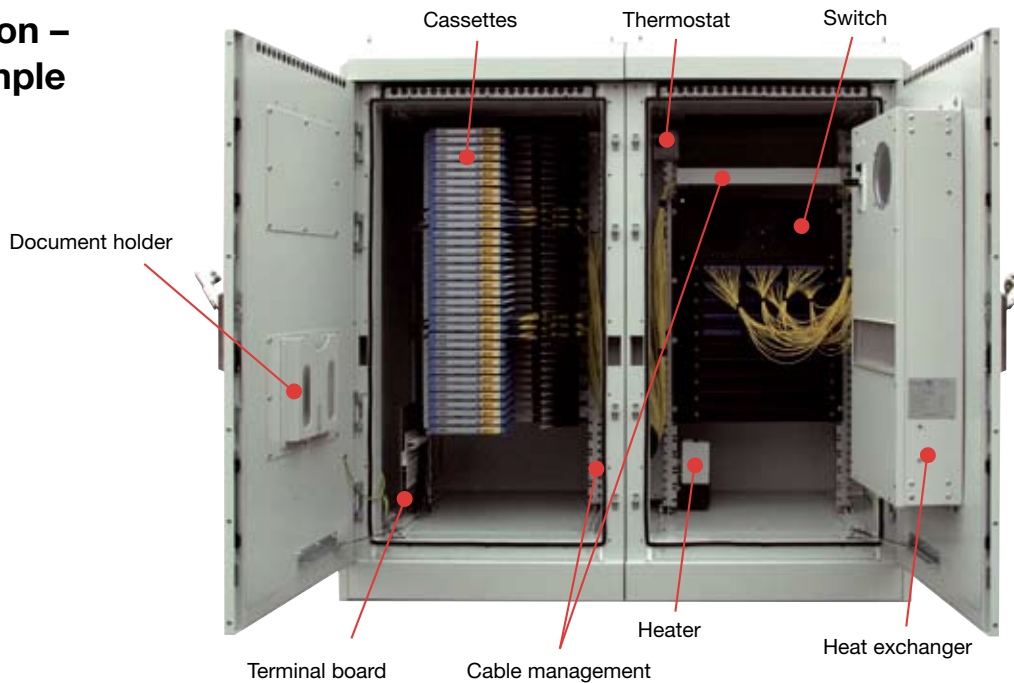

## Transport – how to lift your cabinets safely

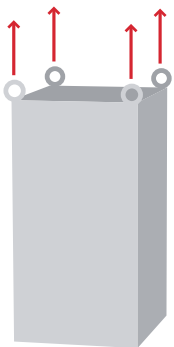

When you need to lift a single cabinet use all four lifting eyes. Aim for a lifting angle of no less than 60 degrees. That way you can safely lift a single cabinet with up to 250 kilos of additional weight.

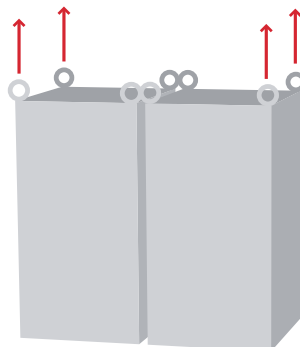

Need to lift a double cabinet? Again aim for a lifting angle of no less than 60 degrees. And if you use the four lifting eyes illustrated above, you can lift a double cabinet with up to 420 kilos of additional weight.

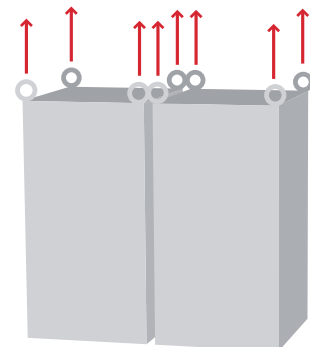

For maximum lift and safety we recommend you use ALL lifting eyes while trying to achieve a lifting angle of as close to 90 degrees as possible.

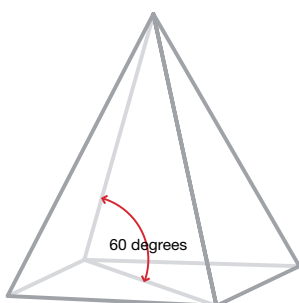

If you need to lift a large cabinet construction or have to carry even more additional weight, please contact Triax and we will help you out. A damaged cabinet is something we know is such a hassle ...

# Technical information

## Standards

Climate Cabinet Orion (CCO) is certified according to the following international standards.

### IEC 60529 / EN 60529

International Protection code (IP) – against dust and water. IP6X (dust test) and IPX5 (water test).

During the IPX5 test both the heat exchanger and the ventilator at the top of the cabinet were running.

### UL 50

Type 12 (UL)/ Working equipment.

### EN 14511

Climate test.

### ETS 300 753 / ISO 7779 EN ISO 3744, 3746

### ASTM-D 4169, DIN EN 60335-2-40

Transport test / shock and vibration – in accordance with ETS 300019-1-2 part 2.3.

The transport test simulates the real situation of a cabinet travelling by truck from A to B. To do this, we expose the cabinet to frequencies from 4 to 200 Hz for a period of three hours – following the ASTM-D 4169 standard. This test determines if the cabinet (or any other unit) can handle the inevitable vibrations of transport. Method of vibration: Random.

### EN 60728-11 and EN 60950-1

Temperature test (max. 1000 watt).

### EN 60439-1 and EN 60950-1

Earthing.

### EN 60439-5

Mechanical endurance.

### EN 62208

Enclosures for low voltage electrical equipment. General requirements for empty enclosures.

### EN 60728-11

Cable network for TV signals, sound signals and interactive use. Part 11: Safety.

## Corrective maintenance – how to keep your cabinets in good shape

We've spent hours of our time and years of our expertise in designing your Orion climate control cabinet, which will give you many years of trouble-free service. However, we also know that no matter how hard we work for you, we can't stop unfortunate situations happening in the real world.

Cabinets, like people, homes and cars sometimes need a little care – and good maintenance practice is something we understand is key to preserving your investment. So, should the worst happen and the cabinet coating gets damaged, simply clean up the damaged part and remove rust and loose flakes of corrosion. Cleanse areas with white and red rust – and paint the damaged areas, using a suitable automotive grade air-drying paint.

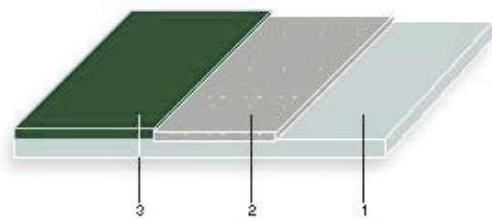

Steel

1: Galvanised steel sheet

2: Min. 20 µm zinc layer

3: 80 - 100 µm polyester

# Climate conditions and control

## Flow diagram, active and passive convection

The Orion cabinet concept offers module-based climate and cooling equipment. This allows you to gradually expand the number of cabinets needed for your future projects. And when you add more cabinets you can do so without disassembling the existing installation. This means that when heat emission increases – either due to the presence of more connections or equipment in an existing cabinet, or as you install extra units alongside – you simply add the necessary cooling module/s as you go along.

Below you will see some examples of the air and heat flow in your cabinets.

**Example 1.** Notice how the double-walled construction creates a chimney effect on all four sides of the cabinet. Natural ventilation and a typical gentle wind of less than 1 metre per second generates a 15 W/K cooling effect.

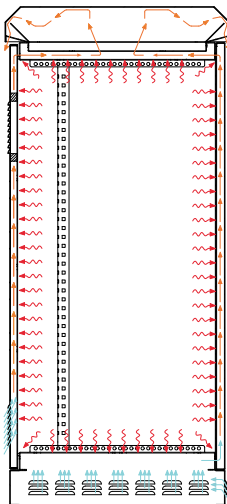

Example 1

**Example 2.** You can easily intensify the chimney effect by mounting a fan at the top of the cabinet. When you do this, your cabinet virtually works as a huge heat exchanger – which boosts the natural cooling effect considerably.

The fan itself increases the chimney effect by approximately 50 percent. Also, if you use an internal fan or switch, additional air flow is created inside the cabinet – this generates

a 24 W/K cooling effect during a gentle wind of less than 1 metre per second. These results were achieved while keeping the overall noise **below 40 dB(A)**.

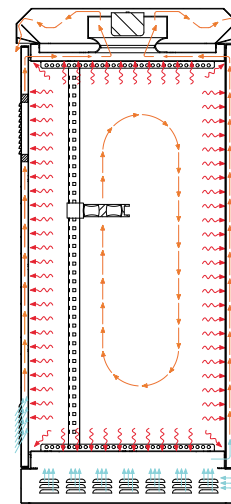

Example 2

**Example 3.** You may also mount a heat exchanger in the cabinet door, which at the same time allows an active chimney effect on all four sides. During a gentle wind of less than 1 metre per second, the heat exchanger and the chimney effect combined give you a 48 W/K cooling effect. These results were achieved despite the deliberately restricted efficiency of the heat exchanger – in order to keep the overall noise below 40 dB(A).

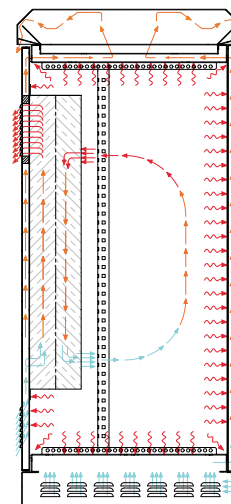

Example 3

# Climate conditions and control

**Example 4.** For optimal cooling, you can use both a heat exchanger and a fan at the top of the cabinet. During a gentle wind of less than 1 metre per second, the heat exchanger and the fan-boosted chimney effect combined give you a 53 W/K cooling effect. These results were achieved despite the deliberately restricted efficiency of the heat exchanger – in order to keep the overall noise below 40 dB(A).

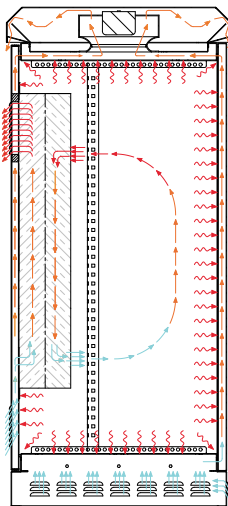

Example 4

## How to pick the proper climate equipment for your project

When you site an outdoor installation you have to pay close attention to the temperature demands and restrictions of your equipment: Consider the geographical location of your cabinet – and whether you have to place it in a restricted and confined backyard or outside in a field somewhere. Where you mount your cabinet should determine your choice of climate equipment.

If you site a cabinet in Northern Norway, outside temperatures are substantially lower compared to Southern France. And the outside temperature heavily influences the cabinets own cooling capabilities.

Sometimes, as in Northern Scandinavia, your real challenge is not how to keep your equipment cool, but how to heat it. Dependent on where you mount the cabinet – plus the time

of day and the accumulating heat from the sun – temperatures may typically vary from -30 to +40 degrees Celsius. These considerations are important every time you choose climate equipment for a new project.

Are you mounting a cabinet in Southern Europe – or someplace else with outside temperatures often exceeding 40 degrees Celsius? Then you need to be particularly cautious about the equipment you use inside the cabinet. Quite often, the cabinets contain traditional indoor equipment with an operating temperature of typically 0 to 50 degrees Celsius.

If the heat emission from the equipment is too high, your cabinet's natural chimney effect will be insufficient – as it is the outside temperature that is used for cooling. In that case, assisted cooling such as fans or air-to-air heat exchangers may be useful.

Indeed an air-conditioning system might be necessary if the maximum allowed outside and inside temperature difference is less than 10 degrees Celsius, or if the cabinet sits in a con-fined space with virtually no air circulation – allowing the air temperature to climb continuously all day long.

As a general rule, you can use a hermetic air-to-air heat exchanger to its optimal potential, if the maximum allowed outside and inside temperature difference is more than 10 degrees Celsius. And though the natural chimney effect helps cool the equipment, you can increase the total cooling capacity by adding a heat exchanger – and yet, you are still only using the outside temperature to cool things down.

# Climate conditions and control

## Heat absorption from sunlight – and how to deal with it

Sunlight affects the heat absorption and heat emission of your outdoor cabinets. During the course of the day, the angle of the sunlight varies. About 50 percent of the cabinet will be in the shade. Hence, individual parts of the cabinet will be affected by the heat from the sun in different ways – and to a different extent. Perhaps the front of the cabinet is exposed to direct sunlight for 4, 5 or 6 hours, while the backside is in the shade all day.

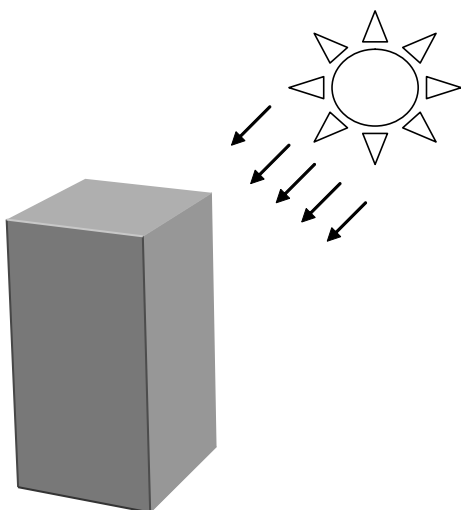

If you compare a single-walled cabinet to a double-walled cabinet, you will find that they have very different heat absorption. Single-walled cabinets heat up inside a lot faster than double-walled cabinets. So, if you go for single-walled cabinets you will probably need more extensive climate equipment. Double-walled constructions on the other hand benefit from the chimney effect which actually decreases the heat absorption.

When you need to calculate the heat absorption in order to pick the perfect climate equipment for your cabinet, there are many elements to consider. However, here at Triax we do these calculations all the time, and we will be happy to help you.

**Simply give us a call, and let us calculate the right solution for you. To estimate this, we need to know a few simple details:**

- Dimensions of your cabinet (height, width & depth)
- Minimum & maximum temperature occurring outside the cabinet (Degrees Celsius)
- Minimum & maximum temperature needed for the equipment inside (Degrees Celsius)
- Heat emission from installed equipment (Watt)
- Location (detached/free-standing, up against a wall, in a corner, in a sheltered place, in the shade etc.)
- Colour

## What we mean by air humidity (condensation) – a definition

Relative air humidity is defined as the relation between the present amount of water vapour in a given mass of air – and the maximum amount of water vapour the mass of air can contain. This depends on the temperature and pressure of the mass of air. Relative air humidity is usually expressed in values from 0 to 100 percent.

The amount of water vapour air can contain increases as temperatures rise. For that reason, the relative humidity of a mass of air drops if the air heats up. Similarly, the relative air humidity goes up if the air temperature drops. Naturally, if cooling continues, at some point the relative air humidity reaches 100 percent – and the water vapour starts condensing. We can see this well-known process every night when dew falls.

Several factors contribute to condensation. As a rule, if you keep the inside surface temperature above 15 degrees Celsius your equipment should be safe. Also, make sure the cabinet is kept tight – or sealed – towards the ground to prevent humidity from working its way into the cabinet from that direction.

# TRIAX A/S

Bjoernkaervej 3 • 8783 Hornsyld • Denmark  
+45 76 82 22 00 • +45 76 82 23 80  
mail: triax@triax.dk • www.triax-cabinets.com



## Triax Austria GmbH

Oberer Paspelsweg 6-8  
6830 Rankweil - Austria  
Tel.: +43 55 22 307 0  
Fax: +43 55 22 307 394  
e-mail: office@triax.at  
web: www.triax.at

## Triax Finland

Malminkaari 5  
FIN-00 700 Helsinki  
Finland  
Tel: +358 9 347 8470  
Fax: +358 9 386 7156  
e-mail: triax.fi@triax.dk  
web: www.triax.fi

## Triax Sarl

13 rue du Chemin de Fer  
ZAC Lampertheim - Cedex  
F - 67451 Mundolsheim Cedex  
France  
Tel: +33 38 81 80 909  
Fax: +33 38 81 80 900  
e-mail: sc@triax.fr  
web: www.triax.fr

## Triax GmbH

Karl-Benz-Strasse 10  
72124 Pliezhausen  
Germany  
Tel.: +49 7127 92 34 0  
Fax: +49 7127 92 34 10  
e-mail: info@triax-gmbh.de  
web: www.triax-gmbh.de

## Triax Kft.

Rokolya u. 1-13  
1131 Budapest  
Hungary  
Tel.: +36 1 349 4199  
Fax: +36 1 329 8453  
e-mail: info@triax.hu  
web: www.triax.hu

## Triax Digital Multimedia S.L.

N.I.F. B 28257848  
C/ Ingeniero Torres Quevedo, No 20  
Poligono Fin de Semana  
28022 Madrid • Spain  
Tel.: +34 91 74 828 36  
Fax: +34 91 32 961 47  
e-Mail: hms@triaxmultimedia.es  
web: www.triaxmultimedia.es

## Triax Svenska AB

Kolfallsgatan 5  
S-582 73 Linköping  
Sweden  
Tel: +46 13 14 41 14  
Fax: +46 13 14 41 13  
e-mail: triax@triax.se  
web: www.triax.se

## Triax UK

Abergorki Industrial Estate  
Treorchy - South Wales CF42 6DL  
United Kingdom  
Tel: +44 14 43 77 89 08  
Fax: +44 14 43 77 77 79  
e-mail: sales@triax.co.uk  
web: www.triax.co.uk

## Triax Middle East

PO Box 18351 - Dubai  
United Arab Emirates  
Tel: +971 4 887 3100  
Fax: +971 4 887 3101  
e-mail: triax@triax.ae  
web: www.triax.com

# Your ultimate connection

- we offer you insight, experience and a wide range of solutions

*The Triax Group is among the leaders within two business areas:*

*Triax Multimedia - Reception, distribution and storage of video, audio and data*

*Triax Cabinets - Protection of network equipment*

*Triax was founded in Denmark, Europe in 1949 and has kept growing ever since. 750 employees across the globe generate sales of 170 mill. Euro. We manufacture in Europe and China. We service our customers globally through 10 own companies and a growing net of distributors.*

*The Triax Group is part of Nielsen & Nielsen Holding A/S which is the mother company in an international Danish company and employs more than 2400 employees in 37 companies.*

Find more information at..

[www.triax.com](http://www.triax.com)



TRIAX - your ultimate connection